

80mA, 10V, 3.2 μ A Quiescent Current LOW-DROPOUT LINEAR REGULATOR in SC70 or SON 2x2

FEATURES

- **Wide Input Voltage Range: 2.5V to 10V**
- **Low Quiescent Current: 3.2 μ A at 80mA**
- **Stable with any Capacitor > 0.47 μ F**
- **Output Current: 80mA**
- **Dropout Voltage: 415mV at 50mA Load**
- **Available in Fixed 3.3V or Adjustable (1.2V to 8.8V) Versions**
- **Current Limit**
- **SC70-5 and 2mm x 2mm SON-6 Packages**
- **Specified Junction Temperature Range: –40°C to +125°C**
- **For MSP430-Specific Output Voltages, see the [TPS715xx](#)**

APPLICATIONS

- **Ultralow-Power Microcontrollers**
- **Industrial/Automotive Applications**
- **PDA's**
- **Portable, Battery-Powered Equipment**

DESCRIPTION

The TPS714xx low-dropout (LDO) voltage regulators offer the benefits of wide input voltage range, low-dropout voltage, low-power operation, and miniaturized packaging. These devices, which operate over an input range of 2.5V to 10V, are stable with any capacitor $\geq 0.47\mu\text{F}$. The 2.5V to 10V input voltage range, combined with 3.2 μA quiescent current, makes this device particularly well-suited for two-cell alkaline, and two-cell lithium, and other low quiescent current sensitive battery applications. The low dropout voltage and low quiescent current allow operation at extremely low power levels. Therefore, the devices are ideal for power battery management ICs. Specifically, because the device is enabled as soon as the applied voltage reaches the minimum input voltage, the output is quickly available to power continuously-operating, battery-charging ICs.

The typical PNP pass transistor has been replaced by a PMOS pass element. Because the PMOS pass element behaves as a low-value resistor, the low dropout voltage (typically 415mV at 50mA of load current) is directly proportional to the load current. The quiescent current (3.2 μA , typical) is stable over the entire range of the output load current (0mA to 80mA).

The TPS714xx is available in a 2mm x 2mm SON-6 package ideal for high power dissipation, or an SC70-5 package ideal for handheld and ultra-portable applications.

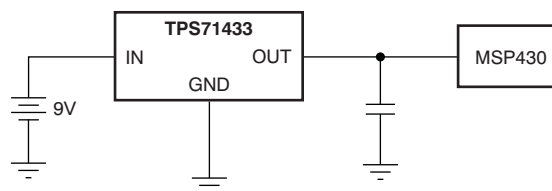
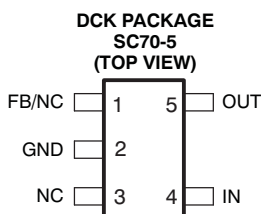
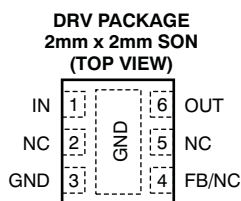

Please be aware that an important notice concerning availability, standard warranty, and use in critical applications of Texas Instruments semiconductor products and disclaimers thereto appears at the end of this data sheet.

All trademarks are the property of their respective owners.



This integrated circuit can be damaged by ESD. Texas Instruments recommends that all integrated circuits be handled with appropriate precautions. Failure to observe proper handling and installation procedures can cause damage.

ESD damage can range from subtle performance degradation to complete device failure. Precision integrated circuits may be more susceptible to damage because very small parametric changes could cause the device not to meet its published specifications.

AVAILABLE OPTIONS⁽¹⁾

PRODUCT	V _{OUT} ⁽²⁾
TPS714xxyyyz	XX is nominal output voltage (for example 33 = 3.3V, 01 = Adjustable) YYY is Package Designator Z is Package Quantity

- (1) For the most current package and ordering information see the Package Option Addendum at the end of this document, or see the TI web site at www.ti.com.
- (2) Custom output voltages are available on a quick-turn basis for prototyping. Production quantities are available; minimum package order quantities apply. Contact factory for details and availability.

ABSOLUTE MAXIMUM RATINGS

Over operating temperature range, unless otherwise noted.⁽¹⁾

PARAMETER	TPS714xx	UNIT
V _{IN} range	–0.3 to +24	V
V _{OUT} range	–0.3 to +9.9	V
V _{FB} range	–0.3 to +4	V
Peak output current	Internally limited	
Continuous total power dissipation	See Power Dissipation Rating table	
Junction temperature range, T _J	–40 to +125	°C
Storage temperature range	–65 to +150	°C
ESD rating	Human body model (HBM)	2 kV
	Charged device model (CDM)	500 V

- (1) Stresses beyond those listed under *Absolute Maximum Ratings* may cause permanent damage to the device. These are stress ratings only, and functional operation of the device at these or any other conditions beyond those indicated is not implied. Exposure to absolute-maximum-rated conditions for extended periods may affect device reliability.

POWER DISSIPATION RATING TABLE

BOARD	PACKAGE	R _{θJA} °C/W	DERATING FACTOR ABOVE T _A = +25°C	T _A ≤ 25°C POWER RATING	T _A = +70°C POWER RATING	T _A = +85°C POWER RATING
High-K ⁽¹⁾	DCK	315	3.18mW/°C	320mW	175mW	100mW
High-K ⁽¹⁾	DRV	65	15.4mW/°C	1.54W	850mW	0.62W

- (1) The JEDEC High-K (2s2p) board design used to derive this data was a 3 inch × 3 inch, multilayer board with 1-ounce internal power and ground planes and 2-ounce copper traces on top and bottom of the board.

ELECTRICAL CHARACTERISTICS

Over the operating junction temperature range ($T_J = -40^\circ\text{C}$ to $+125^\circ\text{C}$), $V_{IN} = V_{OUT(NOM)} + 1\text{V}$, $I_{OUT} = 1\text{mA}$, and $C_{OUT} = 1\mu\text{F}$, unless otherwise noted. The adjustable version is tested with $V_{OUT} = 2.8\text{V}$. Typical values are at $T_J = +25^\circ\text{C}$.

PARAMETER	TEST CONDITIONS	TPS714xx			UNIT	
		MIN	TYP	MAX		
Input voltage range ⁽¹⁾	V_{IN}	$I_{OUT} = 10\text{mA}$	2.5	10	V	
		$I_{OUT} = 80\text{mA}$	3	10		
Output voltage range (TPS71401)	V_{OUT}		V_{FB}	8.8	V	
Internal reference (TPS71401)	V_{FB}		1.12	1.20	1.24	V
Output voltage accuracy ⁽¹⁾	TPS71433 over V_{IN} , I_{OUT} , and Temp $4.3\text{V} < V_{IN} < 10\text{V}$, $1\text{mA} \leq I_{OUT} \leq 80\text{mA}$		3.135	3.3	3.465	V
Output voltage line regulation ⁽¹⁾	$\Delta V_{OUT}/\Delta V_{IN}$ $V_{OUT} + 1\text{V} < V_{IN} \leq 10\text{V}$			5		mV
Load regulation	$\Delta V_{OUT}/\Delta I_{OUT}$ $I_{OUT} = 1\text{mA}$ to 80mA			30		mV
Feedback pin bias current	$I_{FB\ BIAS}$ $I_{OUT} = 0\text{mA}$, $V_{IN} = 3\text{V}$ to 10V , $V_{OUT} = 1.2\text{V}$,			2		nA
Dropout voltage	V_{DO} $I_{OUT} = 80\text{mA}$, $V_{IN} = V_{OUT(NOM)} - 0.1\text{V}$			670	1300	mV
Output current limit	I_{CL} $V_{OUT} = 0\text{V}$			100	1100	mA
Ground pin current	I_{GND}	$T_J = -40^\circ\text{C}$ to $+85^\circ\text{C}$, $1\text{mA} \leq I_{OUT} \leq 80\text{mA}$		3.2	4.2	μA
		$1\text{mA} \leq I_{OUT} \leq 80\text{mA}$		3.2	5.8	
		$V_{IN} = 10\text{V}$, $1\text{mA} \leq I_{OUT} \leq 80\text{mA}$			7.4	
Power-supply ripple rejection	PSRR $f = 100\text{kHz}$, $C_{OUT} = 10\mu\text{F}$			60		dB
Output noise voltage	V_{IN} BW = 200Hz to 100kHz , $C_{OUT} = 10\mu\text{F}$, $I_{OUT} = 50\text{mA}$			575		μVrms

(1) Minimum $V_{IN} = V_{OUT} + V_{DO}$, or the value shown for Input voltage, whichever is greater.

PIN CONFIGURATION

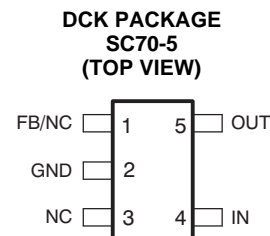
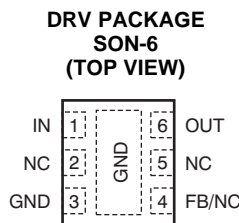

Table 1. Pin Descriptions

TPS714xx					DESCRIPTION
NAME	DCK		DRV		
	FIXED	ADJ.	FIXED	ADJ.	
FB/NC	-	1	-	4	Adjustable version only. This pin is used to set the output voltage.
GND	2	2	3, Pad	3, Pad	Ground
NC	1,3	3	2, 4, 5	2, 5	No connection. May be left open or tied to ground for improved thermal performance.
IN	4	4	1	1	Unregulated input voltage.
OUT	5	5	6	6	Regulated output voltage. Any output capacitor $\geq 0.47\mu\text{F}$ can be used for stability.

FUNCTIONAL BLOCK DIAGRAMS

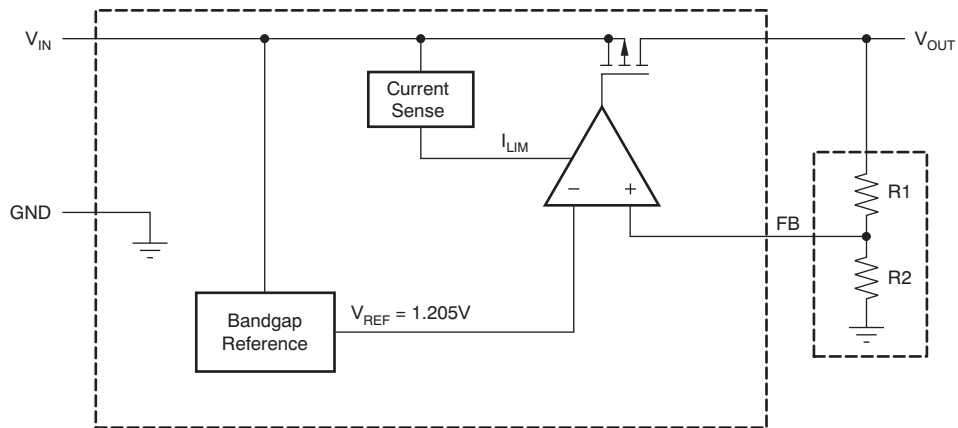

Figure 1. Adjustable Voltage Version

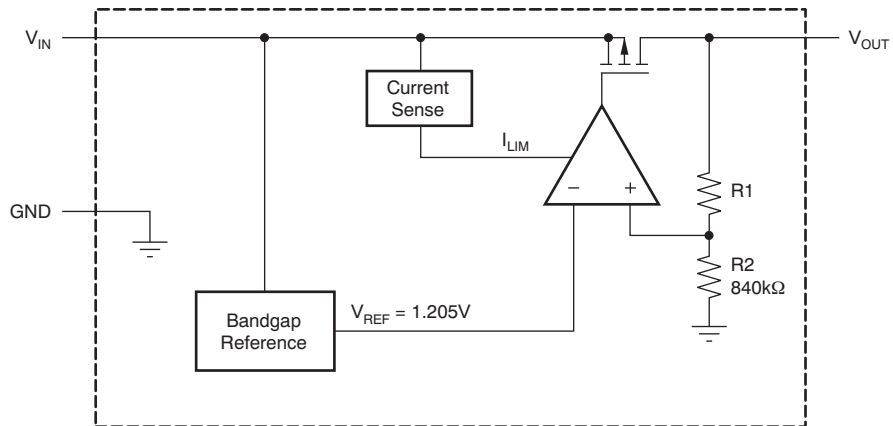

Figure 2. Fixed Voltage Version

TYPICAL CHARACTERISTICS

At $T_A = +25^\circ\text{C}$, unless otherwise noted.

**TPS71433
OUTPUT VOLTAGE
vs
OUTPUT CURRENT**

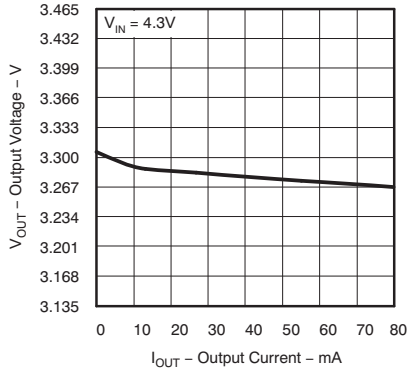

Figure 3.

**TPS71433
OUTPUT VOLTAGE
vs
JUNCTION TEMPERATURE**

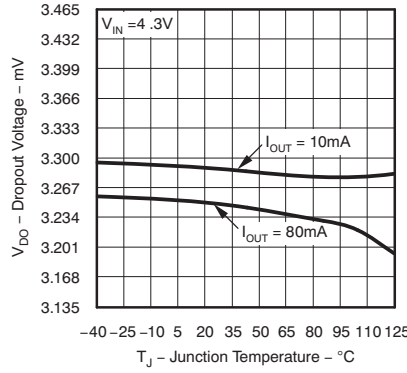

Figure 4.

**TPS71433
QUIESCENT CURRENT
vs
JUNCTION TEMPERATURE**

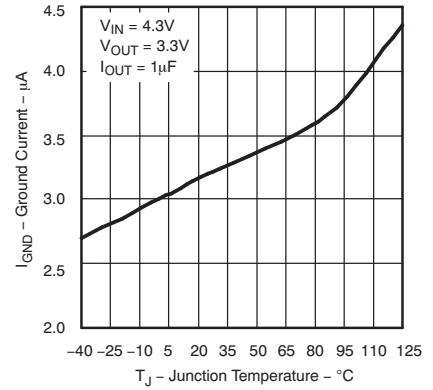

Figure 5.

**TPS71433
OUTPUT SPECTRAL NOISE DENSITY
vs
FREQUENCY**

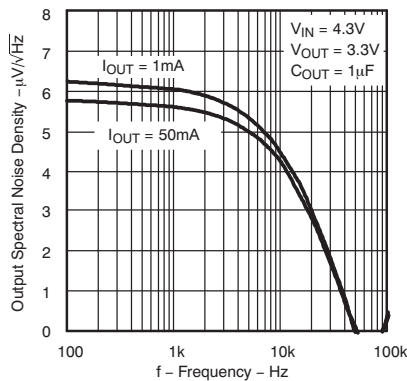

Figure 6.

**TPS71433
OUTPUT IMPEDANCE
vs
FREQUENCY**

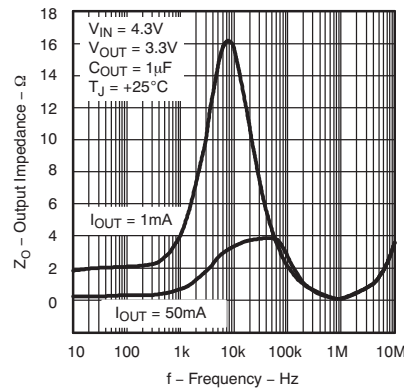

Figure 7.

**TPS71433
DROPOUT VOLTAGE
vs
OUTPUT CURRENT**

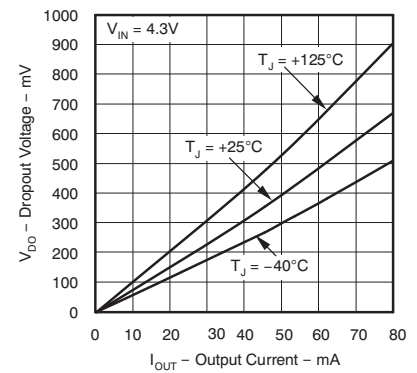

Figure 8.

TYPICAL CHARACTERISTICS (continued)

At $T_A = +25^\circ\text{C}$, unless otherwise noted.

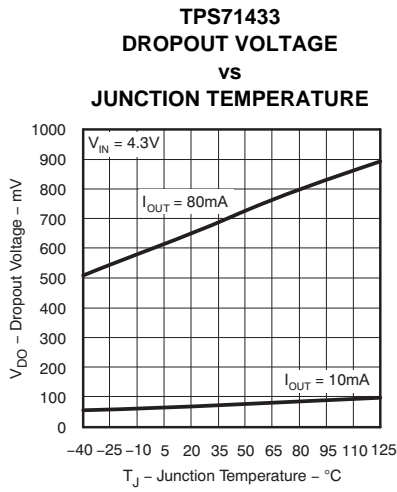

Figure 9.

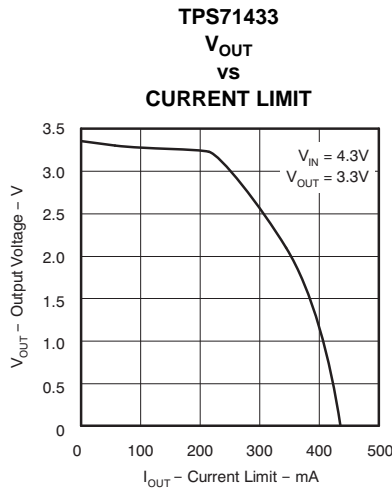

Figure 10.

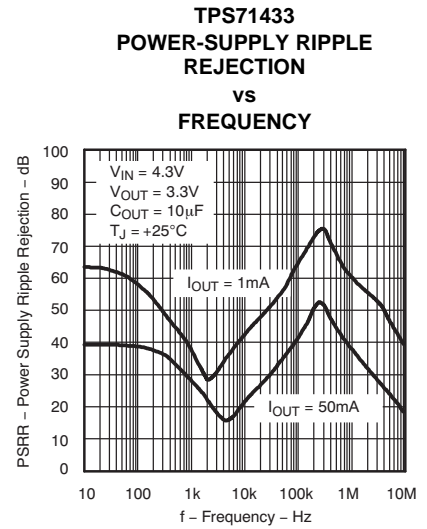

Figure 11.

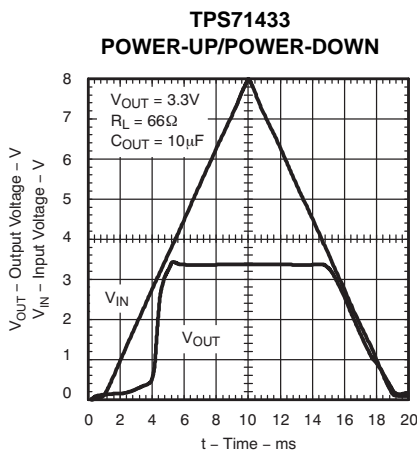

Figure 12.

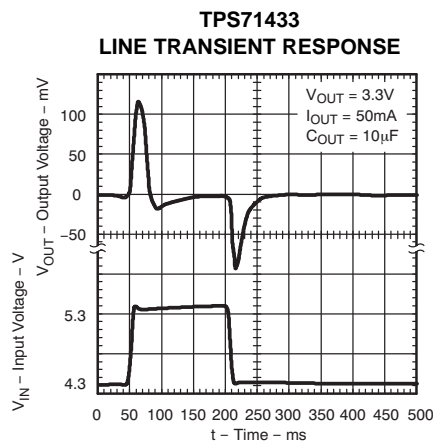

Figure 13.

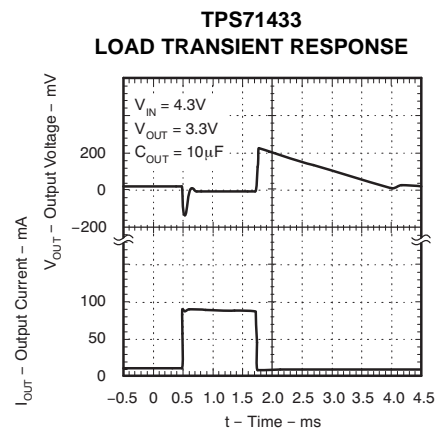

Figure 14.

APPLICATION INFORMATION

The TPS714xx family of LDO regulators has been optimized for ultralow power applications such as the [MSP430](#) microcontroller. Its ultralow supply current maximizes efficiency at light loads, and its high input voltage range makes it suitable for supplies such as unconditioned solar panels.

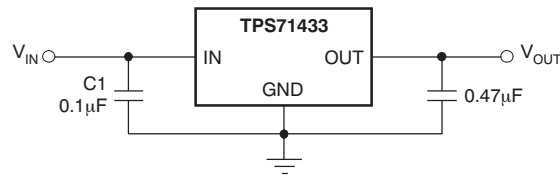

Figure 15. Typical Application Circuit (Fixed Voltage Version)

External Capacitor Requirements

Although not required, a 0.047µF or larger input bypass capacitor, connected between IN and GND and located close to the device, is recommended to improve transient response and noise rejection of the power supply as a whole. A higher-value input capacitor may be necessary if large, fast-rise-time load transients are anticipated and if the device is located several inches from the power source.

The TPS714xx requires an output capacitor connected between OUT and GND to stabilize the internal control loop. Any capacitor (including ceramic and tantalum) that is greater than or equal to 0.47µF properly stabilizes this loop.

Power Dissipation and Junction Temperature

To ensure reliable operation, worst-case junction temperature should not exceed +125°C. This restriction limits the power dissipation that the regulator can manage in any given application. To ensure the junction temperature is within acceptable limits, calculate the maximum allowable dissipation, $P_{D(MAX)}$, and the actual dissipation, P_D , which must be less than or equal to $P_{D(max)}$.

The maximum-power-dissipation limit is determined using [Equation 1](#):

$$P_{D(max)} = \frac{T_{Jmax} - T_A}{R_{\theta JA}}$$

Where:

- T_{Jmax} is the maximum allowable junction temperature.
- $R_{\theta JA}$ is the thermal resistance junction-to-ambient for the package (see the [Power Dissipation Rating](#) table).
- T_A is the ambient temperature.

(1)

The regulator dissipation is calculated using [Equation 2](#):

$$P_D = (V_{IN} - V_{OUT}) \times I_{OUT}$$

(2)

Power dissipation resulting from quiescent current is negligible.

Regulator Protection

The TPS714xx PMOS-pass transistor has a built-in back diode that conducts reverse current when the input voltage drops below the output voltage (for example, during power-down). Current is conducted from the output to the input and is not internally limited. If extended reverse voltage operation is anticipated, external limiting might be appropriate.

The TPS714xx features internal current limiting. During normal operation, the TPS714xx limits output current to approximately 500mA. When current limiting engages, the output voltage scales back linearly until the over-current condition ends. There is no internal thermal shutdown circuit in this device; therefore, care must be taken not to exceed the power dissipation ratings of the package during a fault condition. This device does not have undervoltage lockout; therefore, this constraint should be taken into consideration for specific applications.

Programming the TPS71401 Adjustable LDO Regulator

The output voltage of the TPS71401 adjustable regulator is programmed using an external resistor divider as shown in Figure 16. The output voltage is calculated using Equation 3:

$$V_{OUT} = V_{REF} \times \left(1 + \frac{R1}{R2} \right) \quad (3)$$

where:

$$V_{REF} = 1.20V \text{ typ (the internal reference voltage)}$$

Resistors R1 and R2 should be chosen for approximately a 1.5µA divider current. Lower value resistors can be used for improved noise performance, but the solution consumes more power. Higher resistor values should be avoided because leakage current out of the FB pin across R1/R2 creates an offset voltage that artificially increases the feedback voltage and thus erroneously decreases V_{OUT} . The recommended design procedure is to choose $R2 = 1M\Omega$ to set the divider current at 1.5µA, and then calculate R1 using Equation 4:

$$R1 = \left(\frac{V_{OUT}}{V_{REF}} - 1 \right) \times R2 \quad (4)$$

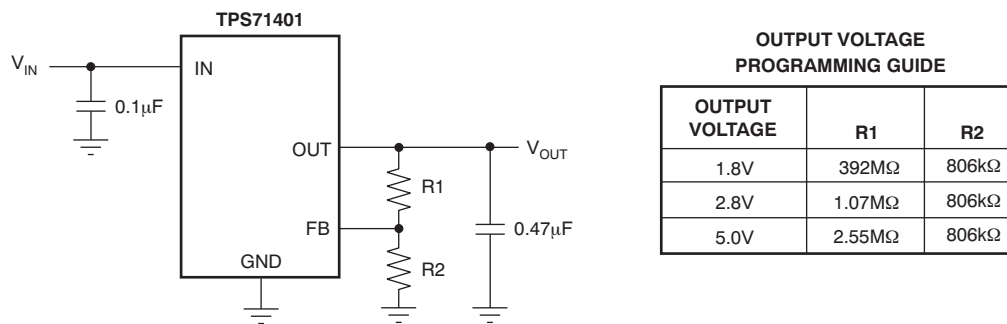

Figure 16. TPS71401 Adjustable LDO Regulator Programming

REVISION HISTORY

NOTE: Page numbers for previous revisions may differ from page numbers in the current version.

Changes from Revision B (December, 2009) to Revision C Page

- Changed *Ground pin current* maximum specifications 3
-

Changes from Revision A (April, 2009) to Revision B Page

- Changed battery type shown in typical circuit illustration 1
 - Changed V_{IN} range absolute maximum rating from +11.5V to +24V 2
-

PACKAGING INFORMATION

Orderable Device	Status ⁽¹⁾	Package Type	Package Drawing	Pins	Package Qty	Eco Plan ⁽²⁾	Lead/ Ball Finish	MSL Peak Temp ⁽³⁾	Samples (Requires Login)
TPS71401DCKR	ACTIVE	SC70	DCK	5	3000	Green (RoHS & no Sb/Br)	CU NIPDAU	Level-1-260C-UNLIM	
TPS71401DCKT	ACTIVE	SC70	DCK	5	250	Green (RoHS & no Sb/Br)	CU NIPDAU	Level-1-260C-UNLIM	
TPS71401DRVR	ACTIVE	SON	DRV	6	3000	Green (RoHS & no Sb/Br)	CU NIPDAU	Level-1-260C-UNLIM	
TPS71401DRVT	ACTIVE	SON	DRV	6	250	Green (RoHS & no Sb/Br)	CU NIPDAU	Level-1-260C-UNLIM	
TPS71433DCKR	ACTIVE	SC70	DCK	5	3000	Green (RoHS & no Sb/Br)	CU NIPDAU	Level-1-260C-UNLIM	
TPS71433DCKT	ACTIVE	SC70	DCK	5	250	Green (RoHS & no Sb/Br)	CU NIPDAU	Level-1-260C-UNLIM	
TPS71433DRVR	ACTIVE	SON	DRV	6	3000	Green (RoHS & no Sb/Br)	CU NIPDAU	Level-1-260C-UNLIM	
TPS71433DRVT	ACTIVE	SON	DRV	6	250	Green (RoHS & no Sb/Br)	CU NIPDAU	Level-1-260C-UNLIM	

⁽¹⁾ The marketing status values are defined as follows:

ACTIVE: Product device recommended for new designs.

LIFEBUY: TI has announced that the device will be discontinued, and a lifetime-buy period is in effect.

NRND: Not recommended for new designs. Device is in production to support existing customers, but TI does not recommend using this part in a new design.

PREVIEW: Device has been announced but is not in production. Samples may or may not be available.

OBSOLETE: TI has discontinued the production of the device.

⁽²⁾ Eco Plan - The planned eco-friendly classification: Pb-Free (RoHS), Pb-Free (RoHS Exempt), or Green (RoHS & no Sb/Br) - please check <http://www.ti.com/productcontent> for the latest availability information and additional product content details.

TBD: The Pb-Free/Green conversion plan has not been defined.

Pb-Free (RoHS): TI's terms "Lead-Free" or "Pb-Free" mean semiconductor products that are compatible with the current RoHS requirements for all 6 substances, including the requirement that lead not exceed 0.1% by weight in homogeneous materials. Where designed to be soldered at high temperatures, TI Pb-Free products are suitable for use in specified lead-free processes.

Pb-Free (RoHS Exempt): This component has a RoHS exemption for either 1) lead-based flip-chip solder bumps used between the die and package, or 2) lead-based die adhesive used between the die and leadframe. The component is otherwise considered Pb-Free (RoHS compatible) as defined above.

Green (RoHS & no Sb/Br): TI defines "Green" to mean Pb-Free (RoHS compatible), and free of Bromine (Br) and Antimony (Sb) based flame retardants (Br or Sb do not exceed 0.1% by weight in homogeneous material)

⁽³⁾ MSL, Peak Temp. -- The Moisture Sensitivity Level rating according to the JEDEC industry standard classifications, and peak solder temperature.

Important Information and Disclaimer: The information provided on this page represents TI's knowledge and belief as of the date that it is provided. TI bases its knowledge and belief on information provided by third parties, and makes no representation or warranty as to the accuracy of such information. Efforts are underway to better integrate information from third parties. TI has taken and continues to take reasonable steps to provide representative and accurate information but may not have conducted destructive testing or chemical analysis on incoming materials and chemicals. TI and TI suppliers consider certain information to be proprietary, and thus CAS numbers and other limited information may not be available for release.

In no event shall TI's liability arising out of such information exceed the total purchase price of the TI part(s) at issue in this document sold by TI to Customer on an annual basis.

TAPE AND REEL INFORMATION

QUADRANT ASSIGNMENTS FOR PIN 1 ORIENTATION IN TAPE

*All dimensions are nominal

Device	Package Type	Package Drawing	Pins	SPQ	Reel Diameter (mm)	Reel Width W1 (mm)	A0 (mm)	B0 (mm)	K0 (mm)	P1 (mm)	W (mm)	Pin1 Quadrant
TPS71401DRVR	SON	DRV	6	3000	179.0	8.4	2.2	2.2	1.2	4.0	8.0	Q2
TPS71401DRVT	SON	DRV	6	250	179.0	8.4	2.2	2.2	1.2	4.0	8.0	Q2
TPS71433DRVR	SON	DRV	6	3000	179.0	8.4	2.2	2.2	1.2	4.0	8.0	Q2
TPS71433DRVT	SON	DRV	6	250	179.0	8.4	2.2	2.2	1.2	4.0	8.0	Q2

TAPE AND REEL BOX DIMENSIONS

*All dimensions are nominal

Device	Package Type	Package Drawing	Pins	SPQ	Length (mm)	Width (mm)	Height (mm)
TPS71401DRVR	SON	DRV	6	3000	203.0	203.0	35.0
TPS71401DRVT	SON	DRV	6	250	203.0	203.0	35.0
TPS71433DRVR	SON	DRV	6	3000	203.0	203.0	35.0
TPS71433DRVT	SON	DRV	6	250	203.0	203.0	35.0

DCK (R-PDSO-G5)

PLASTIC SMALL-OUTLINE PACKAGE



- NOTES:
- A. All linear dimensions are in millimeters.
 - B. This drawing is subject to change without notice.
 - C. Body dimensions do not include mold flash or protrusion. Mold flash and protrusion shall not exceed 0.15 per side.
 - D. Falls within JEDEC MO-203 variation AA.

DCK (R-PDSO-G5)

PLASTIC SMALL OUTLINE

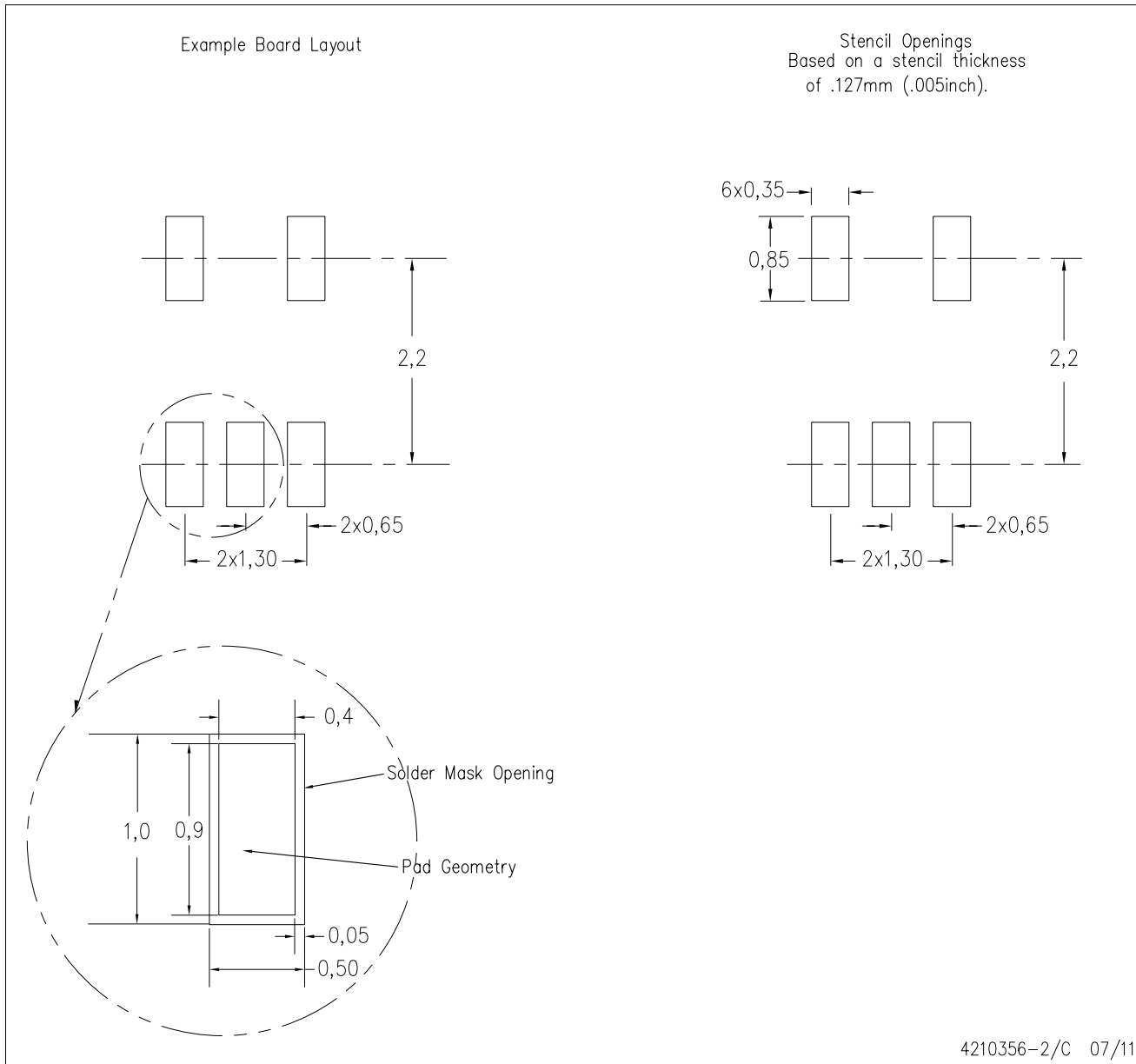

- NOTES:
- All linear dimensions are in millimeters.
 - This drawing is subject to change without notice.
 - Customers should place a note on the circuit board fabrication drawing not to alter the center solder mask defined pad.
 - Publication IPC-7351 is recommended for alternate designs.
 - Laser cutting apertures with trapezoidal walls and also rounding corners will offer better paste release. Customers should contact their board assembly site for stencil design recommendations. Example stencil design based on a 50% volumetric metal load solder paste. Refer to IPC-7525 for other stencil recommendations.

MECHANICAL DATA

DRV (S-PWSON-N6)

PLASTIC SMALL OUTLINE NO-LEAD

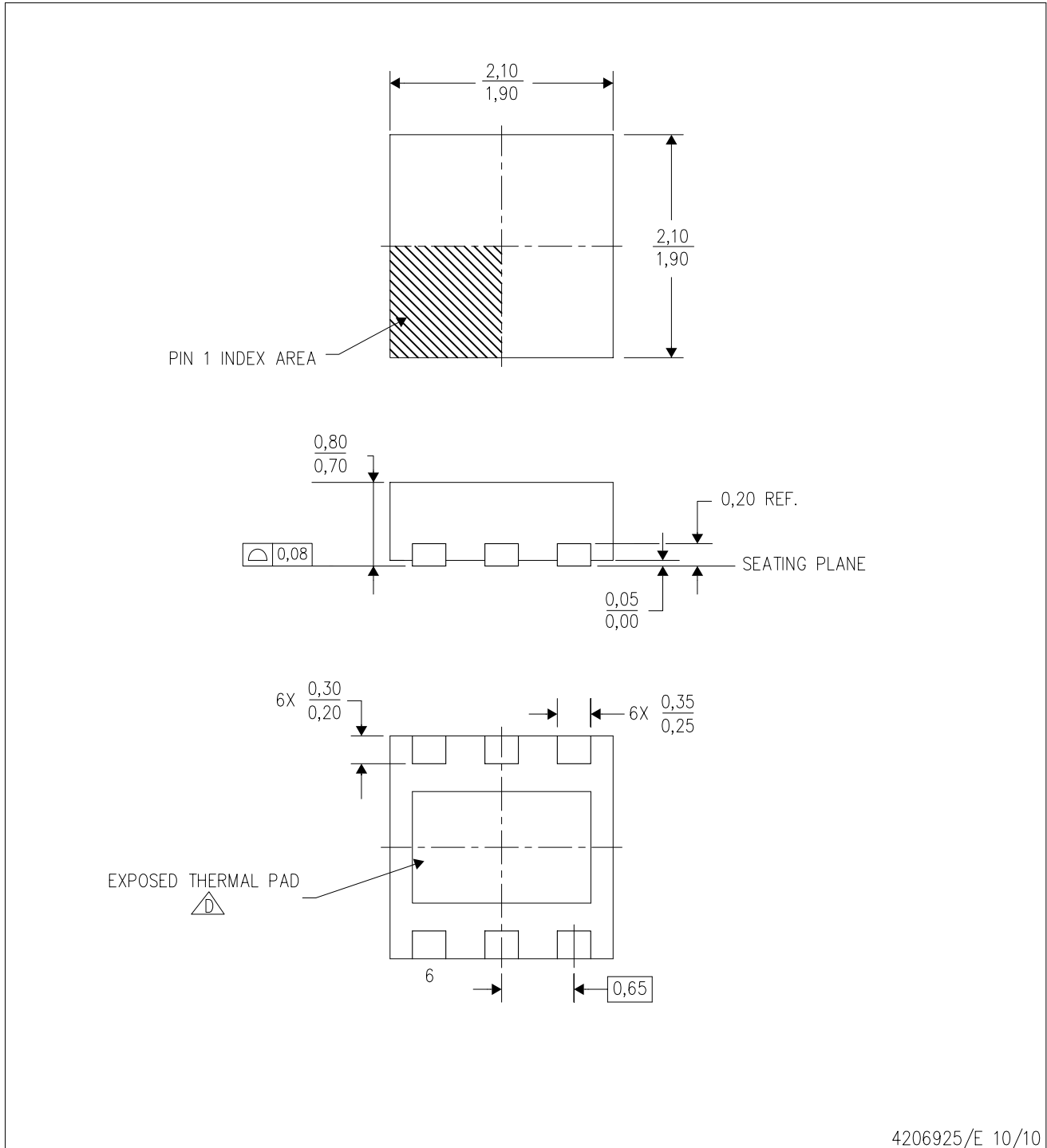

4206925/E 10/10

- NOTES:
- All linear dimensions are in millimeters. Dimensioning and tolerancing per ASME Y14.5M-1994.
 - This drawing is subject to change without notice.
 - Small Outline No-Lead (SON) package configuration.
- $\triangle D$ The package thermal pad must be soldered to the board for thermal and mechanical performance. See the Product Data Sheet for details regarding the exposed thermal pad dimensions.

THERMAL PAD MECHANICAL DATA

DRV (S-PWSON-N6)

PLASTIC SMALL OUTLINE NO-LEAD

THERMAL INFORMATION

This package incorporates an exposed thermal pad that is designed to be attached directly to an external heatsink. The thermal pad must be soldered directly to the printed circuit board (PCB). After soldering, the PCB can be used as a heatsink. In addition, through the use of thermal vias, the thermal pad can be attached directly to the appropriate copper plane shown in the electrical schematic for the device, or alternatively, can be attached to a special heatsink structure designed into the PCB. This design optimizes the heat transfer from the integrated circuit (IC).

For information on the Quad Flatpack No-Lead (QFN) package and its advantages, refer to Application Report, QFN/SON PCB Attachment, Texas Instruments Literature No. SLUA271. This document is available at www.ti.com.

The exposed thermal pad dimensions for this package are shown in the following illustration.

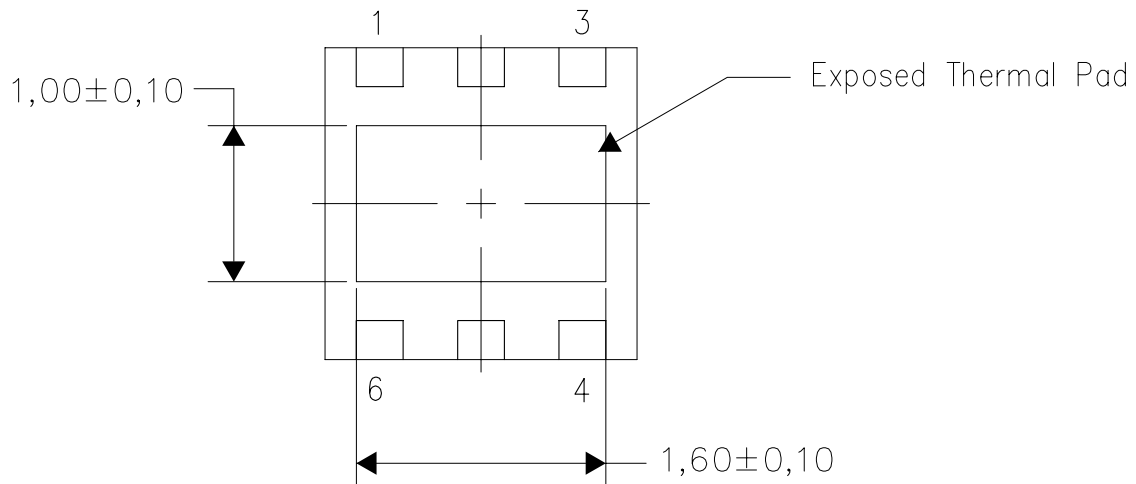

Bottom View

Exposed Thermal Pad Dimensions

4206926/K 04/11

NOTE: A. All linear dimensions are in millimeters

DRV (S-PWSON-N6)

PLASTIC SMALL OUTLINE NO-LEAD

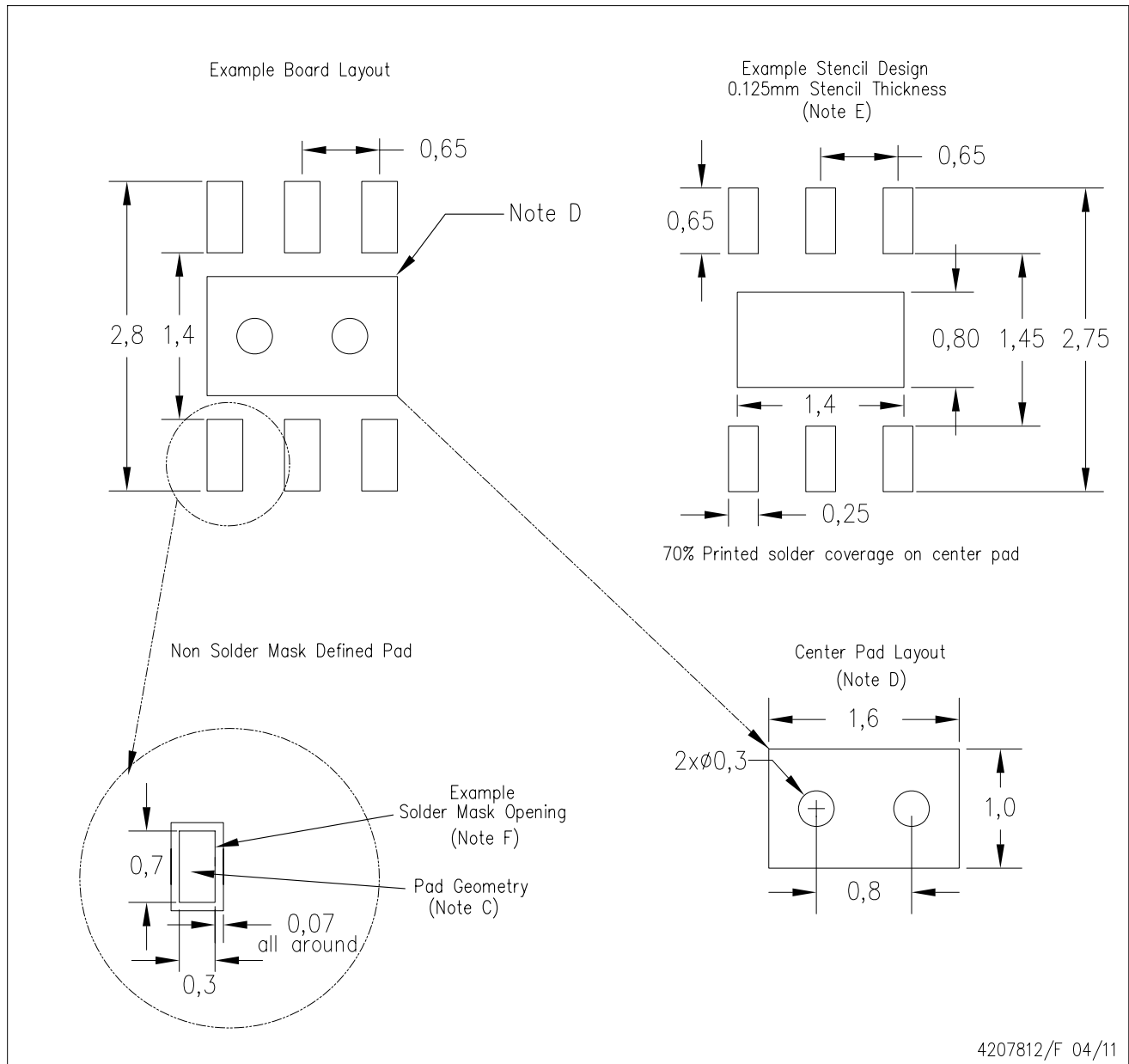

4207812/F 04/11

- NOTES:
- A. All linear dimensions are in millimeters.
 - B. This drawing is subject to change without notice.
 - C. Publication IPC-7351 is recommended for alternate designs.
 - D. This package is designed to be soldered to a thermal pad on the board. Refer to Application Note, QFN/SON PCB Attachment, Texas Instruments Literature No. SLUA271, and also the Product Data Sheets for specific thermal information, via requirements, and recommended board layout. These documents are available at www.ti.com <<http://www.ti.com>>.
 - E. Laser cutting apertures with trapezoidal walls and also rounding corners will offer better paste release. Customers should contact their board assembly site for stencil design recommendations. Refer to IPC 7525 for stencil design considerations.
 - F. Customers should contact their board fabrication site for solder mask tolerances.

IMPORTANT NOTICE

Texas Instruments Incorporated and its subsidiaries (TI) reserve the right to make corrections, modifications, enhancements, improvements, and other changes to its products and services at any time and to discontinue any product or service without notice. Customers should obtain the latest relevant information before placing orders and should verify that such information is current and complete. All products are sold subject to TI's terms and conditions of sale supplied at the time of order acknowledgment.

TI warrants performance of its hardware products to the specifications applicable at the time of sale in accordance with TI's standard warranty. Testing and other quality control techniques are used to the extent TI deems necessary to support this warranty. Except where mandated by government requirements, testing of all parameters of each product is not necessarily performed.

TI assumes no liability for applications assistance or customer product design. Customers are responsible for their products and applications using TI components. To minimize the risks associated with customer products and applications, customers should provide adequate design and operating safeguards.

TI does not warrant or represent that any license, either express or implied, is granted under any TI patent right, copyright, mask work right, or other TI intellectual property right relating to any combination, machine, or process in which TI products or services are used. Information published by TI regarding third-party products or services does not constitute a license from TI to use such products or services or a warranty or endorsement thereof. Use of such information may require a license from a third party under the patents or other intellectual property of the third party, or a license from TI under the patents or other intellectual property of TI.

Reproduction of TI information in TI data books or data sheets is permissible only if reproduction is without alteration and is accompanied by all associated warranties, conditions, limitations, and notices. Reproduction of this information with alteration is an unfair and deceptive business practice. TI is not responsible or liable for such altered documentation. Information of third parties may be subject to additional restrictions.

Resale of TI products or services with statements different from or beyond the parameters stated by TI for that product or service voids all express and any implied warranties for the associated TI product or service and is an unfair and deceptive business practice. TI is not responsible or liable for any such statements.

TI products are not authorized for use in safety-critical applications (such as life support) where a failure of the TI product would reasonably be expected to cause severe personal injury or death, unless officers of the parties have executed an agreement specifically governing such use. Buyers represent that they have all necessary expertise in the safety and regulatory ramifications of their applications, and acknowledge and agree that they are solely responsible for all legal, regulatory and safety-related requirements concerning their products and any use of TI products in such safety-critical applications, notwithstanding any applications-related information or support that may be provided by TI. Further, Buyers must fully indemnify TI and its representatives against any damages arising out of the use of TI products in such safety-critical applications.

TI products are neither designed nor intended for use in military/aerospace applications or environments unless the TI products are specifically designated by TI as military-grade or "enhanced plastic." Only products designated by TI as military-grade meet military specifications. Buyers acknowledge and agree that any such use of TI products which TI has not designated as military-grade is solely at the Buyer's risk, and that they are solely responsible for compliance with all legal and regulatory requirements in connection with such use.

TI products are neither designed nor intended for use in automotive applications or environments unless the specific TI products are designated by TI as compliant with ISO/TS 16949 requirements. Buyers acknowledge and agree that, if they use any non-designated products in automotive applications, TI will not be responsible for any failure to meet such requirements.

Following are URLs where you can obtain information on other Texas Instruments products and application solutions:

Products

Audio	www.ti.com/audio
Amplifiers	amplifier.ti.com
Data Converters	dataconverter.ti.com
DLP® Products	www.dlp.com
DSP	dsp.ti.com
Clocks and Timers	www.ti.com/clocks
Interface	interface.ti.com
Logic	logic.ti.com
Power Mgmt	power.ti.com
Microcontrollers	microcontroller.ti.com
RFID	www.ti-rfid.com
RF/IF and ZigBee® Solutions	www.ti.com/lprf

Applications

Communications and Telecom	www.ti.com/communications
Computers and Peripherals	www.ti.com/computers
Consumer Electronics	www.ti.com/consumer-apps
Energy and Lighting	www.ti.com/energy
Industrial	www.ti.com/industrial
Medical	www.ti.com/medical
Security	www.ti.com/security
Space, Avionics and Defense	www.ti.com/space-avionics-defense
Transportation and Automotive	www.ti.com/automotive
Video and Imaging	www.ti.com/video
Wireless	www.ti.com/wireless-apps

TI E2E Community Home Page

e2e.ti.com

Mailing Address: Texas Instruments, Post Office Box 655303, Dallas, Texas 75265
Copyright © 2011, Texas Instruments Incorporated